

CL5000JSERIES

Label Printing Scale

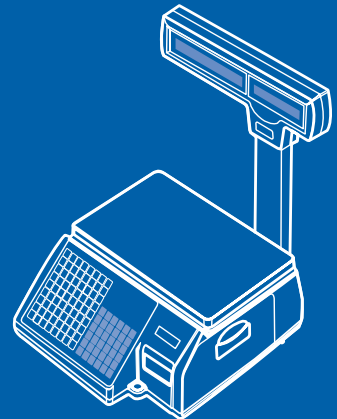

CAS

Table of Contents

1.GENERAL	6
1.1 PRECAUTIONS.....	6
1.2 INTRODUCTIONS.....	8
1.3 SPECIFICATIONS.....	9
1.4 NAME AND FUNCTIONS.....	11
1.5 Basic set - up.....	15
1.6 SYMBOLS.....	16
1.7 KEY FUNCTIONS.....	17
1.8 Installation of the Label Roll.....	20
2. PROGRAMMING	22
2.1 PLU Programming.....	26
2.1.1 Create By-Weight PLU (Menu code 1120).....	27
2.1.2 Create By-Count PLU (Menu code 1120).....	33
2.1.3 Create By-PCS PLU (Menu code 1120).....	34
2.1.4 Editing PLU (Menu code 1120).....	36
2.1.5 Expand PLU (Menu code 1144).....	36
2.1.6 Listing PLU (Menu code 1150).....	36
2.2 Programming PLU Data Table I.....	37
2.2.1 New/Edit Sales Message (Menu code 1240).....	37
2.2.2 Origin (Menu code 1250).....	38
2.2.3 Barcode (Menu code 1260).....	39
2.2.4 Tare (Menu code 1270).....	41
2.2.5 List Unit Symbol (Menu code 1280).....	42
2.3 Programming PLU Data Table II.....	43
2.3.1 Ingredient (Menu code 1310).....	43
2.4 Speed Key Setting.....	44
2.4.1 Speed Key (Menu code 1160).....	44
2.5 Programming Store Data.....	45
2.5.1 Store Data (Menu code 1410).....	45
2.6 Programming Global Setting.....	46
2.6.1 Global Label Format (Menu code 1510).....	46
2.6.2 Barcode Format (Menu code 1520).....	47
2.7 Printing Programming.....	48
2.7.1 Printing (Menu code 1700).....	48
2.7.2 Inhibit(Select) Printing Items(Menu code 1710).....	48
2.7.3 Printer Hardware (Menu code 1730).....	49
2.7.4 Label Size (Menu code 1732).....	49
2.7.5 Sensor Calibration (Menu code 1733).....	49

2.7.6 Peel Sensor (Menu code 1734).....	49
2.7.7 Print Intensity (Menu code 1735).....	50
2.7.8 Adjust Feed Length (Menu code 1736).....	50
2.7.9 Label Preprint (Menu code 1737).....	50
2.7.10 Printer Initialize (Menu code 1738).....	50
2.8 Programming Scale Configuration.....	51
2.8.1 Department (Menu code 1830).....	51
2.8.2 Date & Time (Menu code 1840).....	52
2.8.3 Change Password (Menu code 1852).....	52
2.8.4 Display Test (Menu code 1861).....	52
2.8.5 A/D Test (Menu code 1862).....	52
2.8.6 Keyboard Test (Menu code 1863).....	52
2.8.7 Chess Printer Test (Menu code 1864).....	52
2.8.8 Printer Sensor Test (Menu code 1865).....	53
2.8.9 Scale Parameter (Menu code 1870).....	53
2.8.10 Clear Memory (Menu code 1890).....	53
2.8.10.1 Clear PLU (Menu code 1891).....	53
2.8.10.2 Clear Table1 (Menu code 1892).....	54
2.8.10.3 Clear Table2 (Menu code 1893).....	54
2.8.10.4 Clear ALL (Menu code 1894).....	54
2.9 Report.....	55
2.9.1 Report Menu (Menu code 1600).....	55
2.9.2 Print Report (Menu code 1610).....	55
2.9.3 Scale Sales Report (Menu code 1611).....	55
2.9.4 PLU Report (Menu code 1612).....	56
2.9.5 Miscellaneous PLU Report (Menu code 1613).....	56
2.9.6 Group Report (Menu code 1614).....	56
2.9.7 Department Report (Menu code 1615).....	57
2.9.8 Hourly Report (Menu code 1616).....	57
2.9.9 Clear All Report (Menu code 1650).....	58
2.10 Communication.....	59
2.10.1 Communication (Menu code 1900).....	59
2.10.2 Network Setting (Menu code 1910).....	60
2.10.3 DHCP (Menu code 1912).....	60
2.10.4 IP (Menu code 1913).....	61
2.10.5 RS232C Setting (Menu code 1915).....	61
3. SALES OPERATION.....	62
3.1 Basic Operation.....	62
3.2 Zero.....	62
3.3 Tare.....	64
3.3.1 Manual Tare Entry.....	64
3.3.2 Weighed Tare Entry.....	64
3.3.3 How to Clear Tare.....	65

3.3.4 Preset Tare.....	65
3.3.5 Successive Tare.....	66
3.3.6 Tare Override.....	66
3.4 Calling Up a PLU.....	67
3.4.1 Using Numeric Key.....	67
3.4.2 Using Speed Key.....	67
3.5 Override (FOR key).....	68
3.5.1 By-Weight PLU.....	68
3.5.2 By-Count PLU.....	69
3.5.3 By-PCS PLU.....	70
3.6 Sales Operation.....	72
3.6.1 Weighed Item Operation.....	72
3.6.2 By Count Item.....	73
3.6.3 By PCS Item.....	74
3.7 Add-Up Transaction.....	76
3.8 Void.....	78
3.9 Return.....	79
3.10 Prepack Key.....	80
3.11 Direct Discount.....	82
3.11.1 % Discount Price Key.....	82
4. Appendix.....	83
4.1 Label Format.....	83
4.2 Fixed Label Format Sample.....	87
4.3 Label Field.....	88
4.3.1 Item Label Field.....	88
4.4 ASCII Code Table.....	90
4.5 Window Character Set Information.....	91

1.GENERAL

1.1 PRECAUTIONS

Warning

Precautions when installing the scale. To ensure that you get the most from your scale, please follow these instruction.

Do not disassemble the scale.

When any damage or defect occurs, contact your CAS authorized dealer immediately for proper repair.

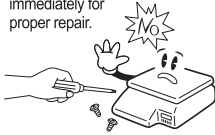

Do not overload beyond the maximum weight limit.

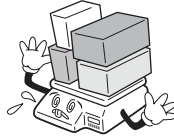

Scale must be grounded to minimize electricity static.

This will minimize defect or electric shock.

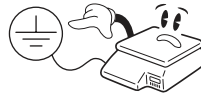

Do not pull the plug by its cord when unplugging.

Damaged cord could cause electric shock or fire.



To prevent from fire occurring, Do not place or use the scale near flammable or corrosive gas.

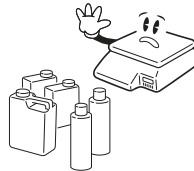

To reduce electric shock or incorrect reading, Do not spill water on the scale or place it in humid condition.

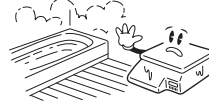

Avoid placing the scale near heater or in direct sunlight.

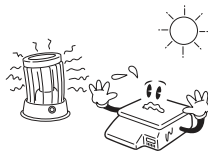

Insert plug firmly to wall outlet to prevent electric shock.

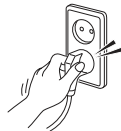

Use proper Adapter.

Incorrect adapter could damage the scale.



Attention

Make sure to plug your scale into the proper power outlet. For maximum performance, plug into a power outlet 30 minutes before the usage for warm up.

For consistent and accurate reading, maintain periodical check by your CAS authorized dealer.



Avoid sudden shock to the scale.



Grab on the bottom of the scale when moving.

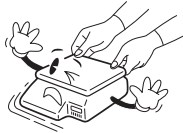

Keep the scale away from other electromagnetic generating devices.

This may interfere with accurate reading.



Place the scale on firm and temperature consistent environment.



By adjusting 4 corners of the scale, set the scale even using the built in scale leveling indicator.

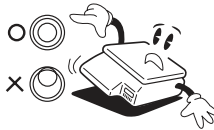

※ This equipment is indoor use and all the communication wirings are limited to inside of the building.

1.2 INTRODUCTIONS

Thank you for purchasing the CAS CL5000J price computing electronic printing scale. We have designed this equipment with many advanced features, high quality construction, and user-friendly menu driven programming. We are confident that you will find the CAS CL5000J scale will meet all of your most demanding needs.

Remember, for proper installation and maintenance please have your Authorized CAS Dealer do the primary installation, programming, and demonstration. Your CAS Authorized Dealer also has a wide variety of supplies, accessories, and expansion options for whatever your new and increasing demands may require. Authorized CAS dealers are trained to help you with every aspect of the CL5000J and should you need servicing, they are expertly trained by CAS to assist you with virtually any problem.

1.3 SPECIFICATIONS

Max. Capacity	3/6kg	6/15kg	15/30kg
Interval	1/2g	2/5g	5/10g
Max. Tare	-2.999kg	-5.998kg	-9.995kg
A/D Conversion Rate	Approx. 8 times/sec.		
Measurement Type	Load Cell		
Platter Size	380 x 244 mm		

Key	Standard Type (B)	48 PLU key, 36 function key	Pole Type (P, R)	72 PLU key, 36 function key
Speed Key		96 PLU		144 PLU
Display	VFD			
	Tare : 4 digit Weight : 5 digit Unit Price : 6 digit Total Price : 6 digit			

Printer	Speed 75 mm/sec.
Printing Resolution	202 dpi
Label Size	Width: 40mm~60 mm Length: 30mm~80 mm
Barcode Type	EAN13, I2OF5, CODE128C
Font	Small, Middle, Large Size, Free Format, Italic, Bold, Underline, Through Line, Double through line, Reverse, shadow, outline
Printer Type	DIRECT THERMAL PRINT

Operating Temp.	-10°C ~ 40°C (14°F ~ 104°F)
Power	AC 100~240V 50/60Hz 1.5A

		Number	Range
Programmable Data	PLU	6000	1~999999
	direct ingredients 300 character	1000	PLU
	Indirect Ingredient 400 character	100	1~100
	User Defined Barcode Format	20	1~20
	Department	99	1~99
	Origin	500	1~500
	Group	99	1~99
	Bitmap Image	5	1~5
	Quantity Symbol	8	1~8
	Report		
	Tare Table	99	1~99
	Label Format	30	1~30
10		51~60	

Sales Period	user selectable reporting period.
Sales Report Mode	Read & Reset

Note: Specifications are subject to change without notice.

1.4 NAME AND FUNCTIONS

OVERALL VIEW

■ Standard Type

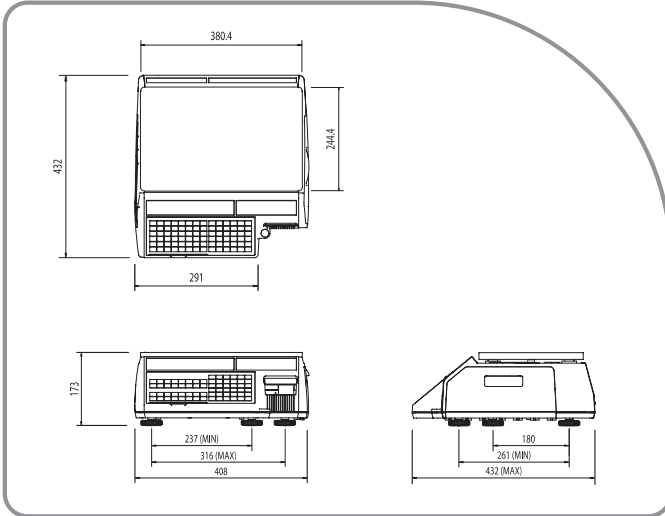

■ Pole Type P

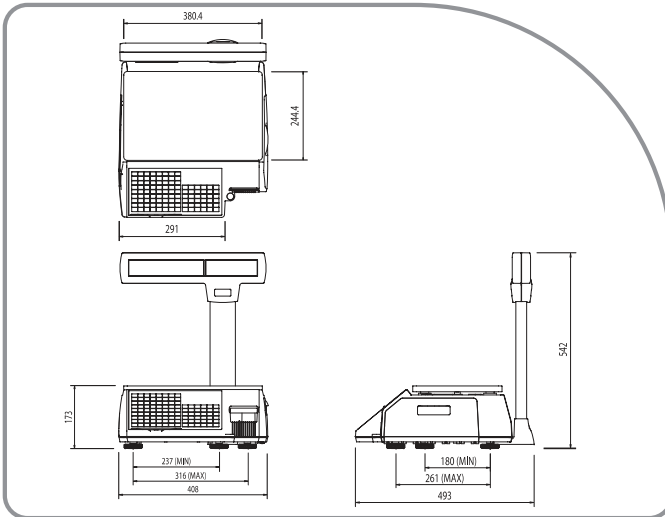

■ Pole Type R

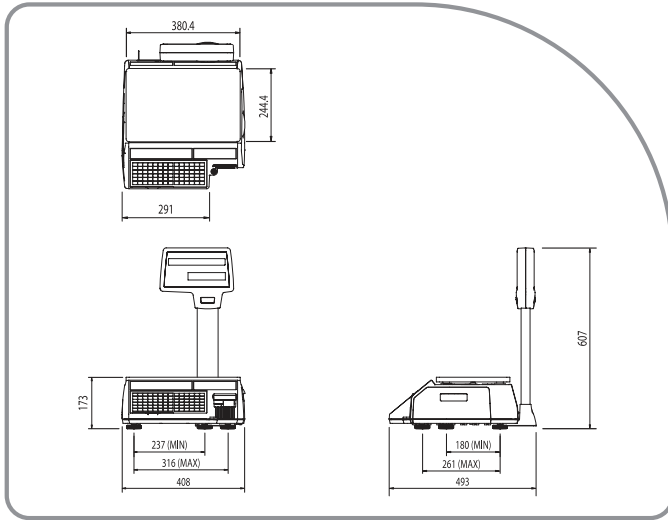

■ Hanging Type

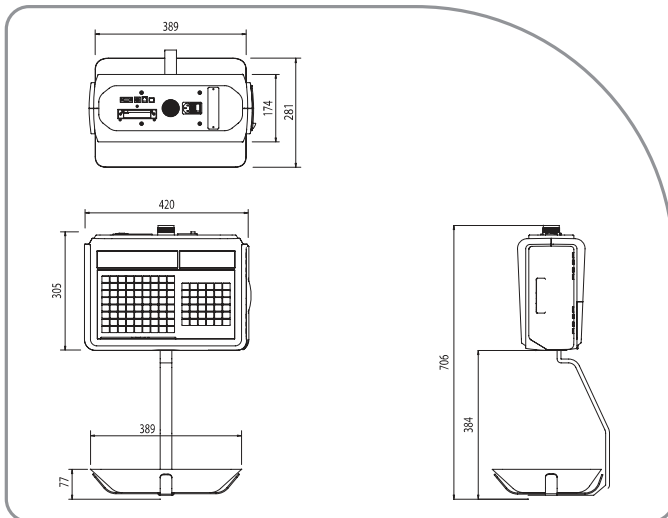

DISPLAY

■ Standard Type (B,P)

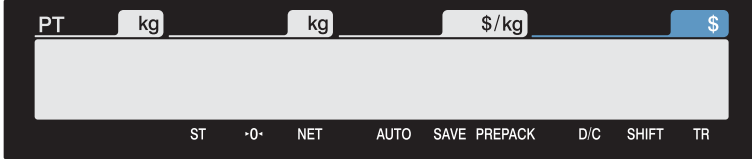

■ Pole Type R

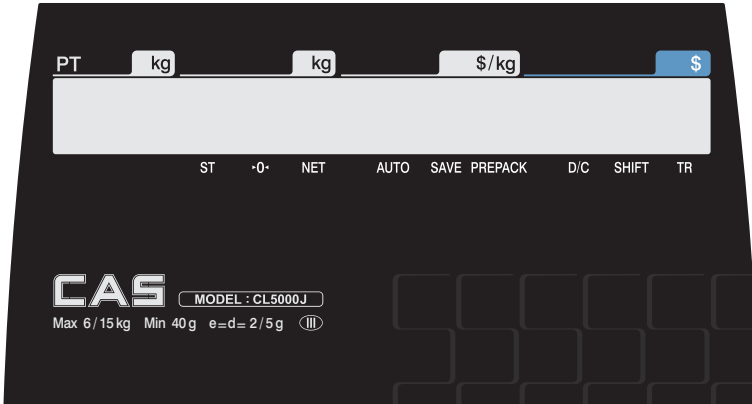

KEYBOARD

Standard

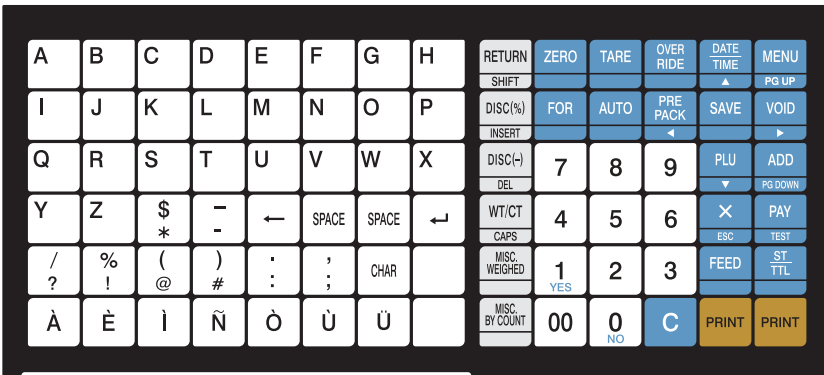

Pole type

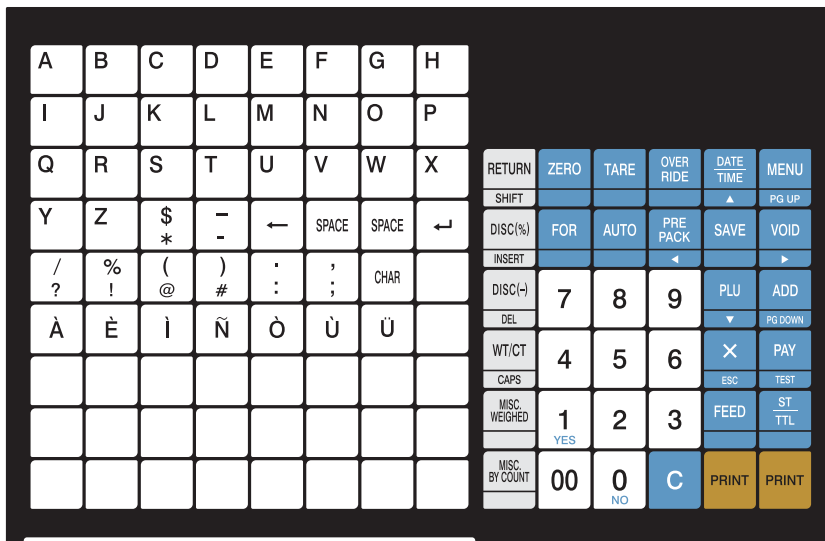

Hanging type

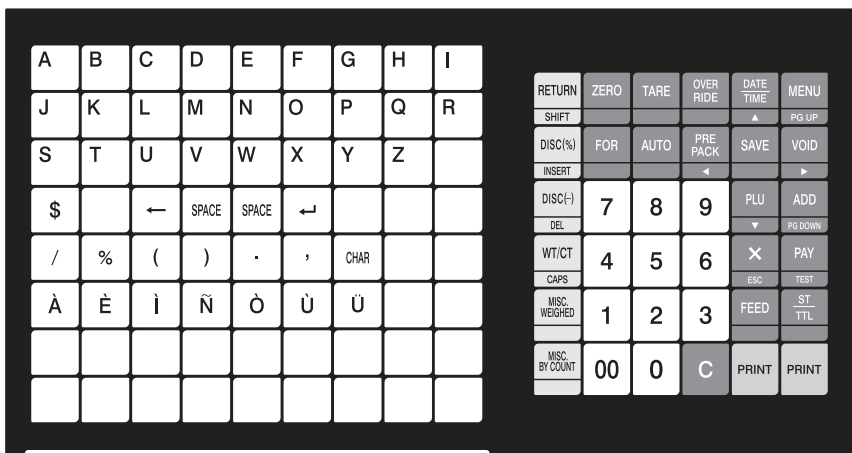

1.5 Basic set - up

How to install tray

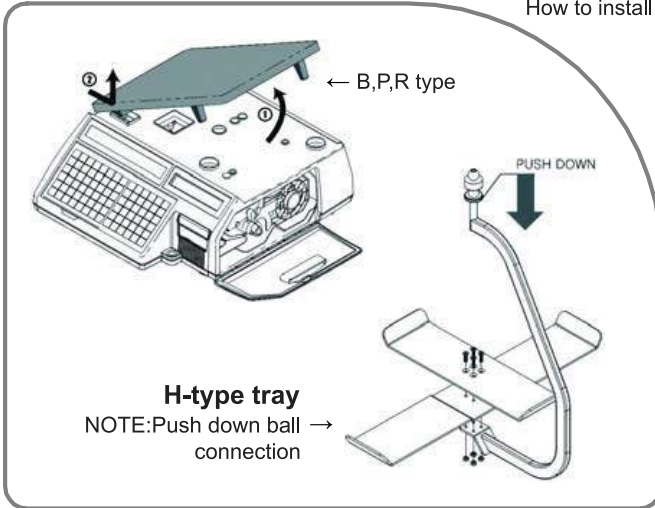



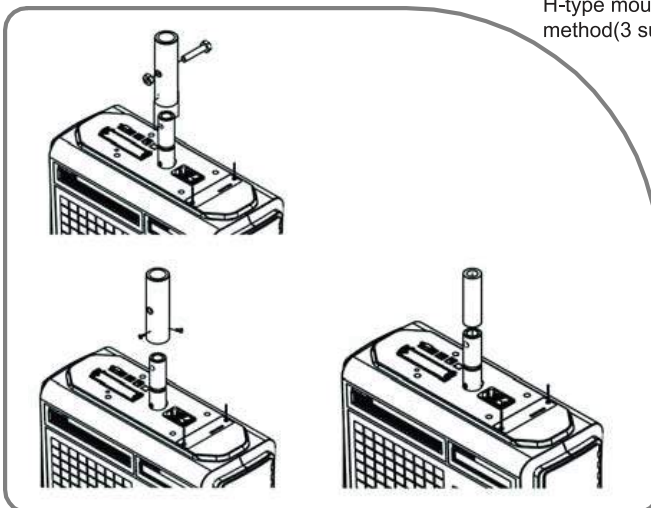











H-type mounting method(3 suggested)























1.6 SYMBOLS

SYMBOLS	DESCRIPTION
ST (▼)	Stable weight indicator
▶0◀	Zero weight indicator
NET (▼)	Net weight indicator
AUTO	Print Mode indicator
SAVE	Auto clearing status indicator
PREPACK	Auto clearing status indicator
DC (▼)	Discount status indicator
SHIFT (▼)	Speed key shift status indicator
TR	Data transmission status indicator

1.7 KEY FUNCTIONS

KEY	DESCRIPTION
	Numeric keys. Used to enter pricing, qty, count, tare, etc.
	Double zero key.
	Clear key. Used to clear erroneous entries and error conditions.
	Re-Zero key. Use to remove small variations in the scale's zero.
	Tare key. Use to manually enter and remove tare weights.
	Override key. For temporary price change entry.
	Date & Time key. Toggles the display between time, date, scale number and department number.
	MENU key. This key toggles from program menu to sale mode. Page up key: only CL5000
	For key. Use this key for by- count or by pcs pricing: 1 / 3 FOR \$1.00. It toggles between the QTY, PIECE, and PRICE fields.
	AUTO key. Auto-print mode
	Pre-Pack key. Used to enter Pre-Packaging mode in which the scale Auto-prints for every transaction and prevents the auto clearing of data.
	Save key. Save mode prevents the auto clearing of any called-up data like tare weight, PLU pricing, etc.
	Void key. To remove erroneous sales from ADD-Up
	When you type a PLU number and press this key, it calls-up that PLU.

KEY	DESCRIPTION
	ADD-Up key. This key when used in conjunction with ST/TTL key allows you print a customer-total label as well as individual transaction labels. Page Down key. only CL5000
	Multi-Label key. Use this key to print multiple sales of the same transaction. Escape key. It is used to exit in program mode.
	Subtotal / Total key. Used with the ADD key in order to print customer-totals.
	Feed key. Use this key to feed labels or paper through printer
	Pay key. Use this key to calculate change. Test key.
	Print key. Used to manually print transactions and also serves as an ENTER key.
	Return key. Used to credit sales for erroneous transactions or returns. Shift Key. Used to SHIFT function in program Mode
	Discount % key. Used to discount price. Insert key: only CL5000
	WT/CT key. Toggles between Weight PLU and Count PLU. CAPS Key: Used to type a small letter in program mode.
	Miscellaneous By-Weight PLU key.
	Miscellaneous By-Count PLU key.
	Negative Discount DELETE key. CL5000 only

KEY	DESCRIPTION
	Alpha keys. Used to type text data.
	Used to type \$
	Backspace key. Used to backspace and delete text data.
	Space bar.
	Used to go to next line to enter text
	Special symbol keys.
	Used to type special symbol. (See ASCII code table on page 192)
	For future

Note: X key is only used in sale mode and ESC key is only used in program mode.

Sale mode : X key

Program mode : ESC key



1.8 Installation of the Label Roll

• Label Specifications

Outer diameter of roll : 100mm

Inner diameter of roll : 40mm

Width of receipt roll : 40, 50, 60mm

Width of label roll : 60mm(MAX)

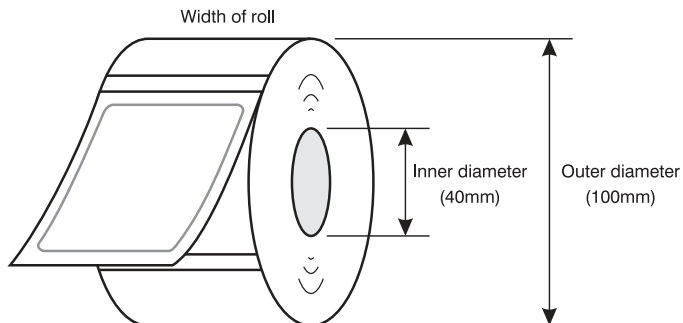

• Print Area

Width of label : 60mm(MAX)

Length of label : 80mm(MAX)

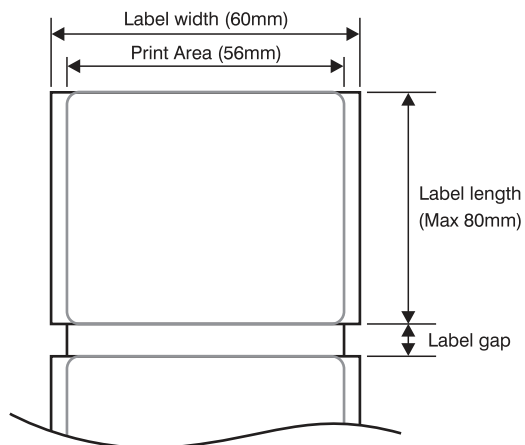

To install the label roll at ANY time you must follow the directions in this section:

1 Turn lever to open position.

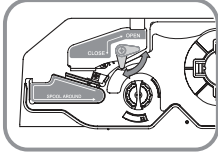

2 Remove the cartridge.

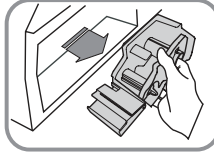

3 Remove the front cover.

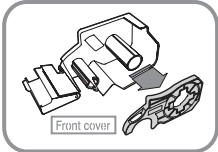

4 Insert the roll paper.

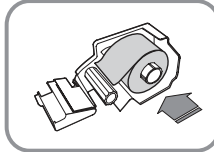

5 Spool the paper to unwinder.

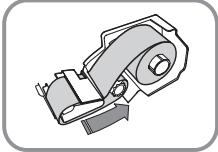

6 Push the clip until it clicks.

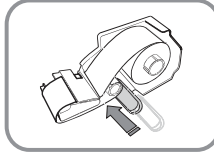

7 Turn the clip for several times.

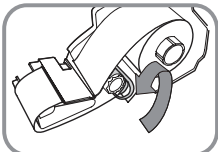

8 Close the front cover.

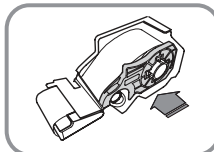

9 Press the FEED key two or times for auto Label adjustment

*If label position is not correct, you have to check follows :

- a. Label size.(Label setting menu)
- b. Feed Adjustment .(Feed adjustment menu)
- c. Sensor calibration(Sensor Calibration menu)

2. PROGRAMMING

Program Mode Menu Tree (Menu code : 1000)

CODE	Menu	CODE	Sub Menu	CODE	Sub Menu
1100	PLU	1120	New/Edit		
		1144	Expand		
		1150	LIST		
		1160	Speed Key		
1200	PLU Data Table 1	1240	Sales Message		
		1250	Origin		
		1260	Barcode		
		1270	Tare		
		1280	Unit Symbol		
1300	PLU Data Table 2	1310	Message		
1400	Store Data Table	1410	Store		
1500	Global Setting	1510	Label Format		
		1520	Barcode		
1600	Report	1610	Report Print	1611	Scale
				1612	PLU
				1613	Misc. PLU
				1614	Group
				1615	Department
				1616	Hourly
		1650	Clear All		
1700	Printing	1710	Print Label Item		
		1730	HW Setting	1732	Label Size
				1733	Sensor Calibration
				1734	Peel Sensor
				1735	Print Intensity
				1736	Adjust Feed Length
				1737	Label Preprint
				1738	Initialize Printer

CODE	Menu	CODE	Sub Menu	CODE	Sub Menu	
1800	Scale Config	1830	Department/Store/speed key number			
		1840	Date/Time			
		1852	Change Password			
		1860	Test	1861	Display	
				1862	A/D	
				1863	Keypad	
				1864	Chess Printer	
				1865	Printer Sensor	
		1870	Scale Parameter			
		1890	Clear Memory	1891	PLU	
				1892	Table1	
1893	Table2					
1894	All					
1912	DHCP					
1900	Communication	1910	Network Setting	1913	IP	
				1915	RS232C Baudrate	

How to access PROGRAM MODE

You can see the Program Menu screen by pressing the MENU key.

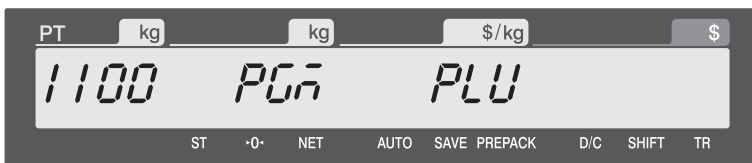

You can use both keys, DATE-TIME/▲ and PLU/▼ to move other menu. Once you choose a proper menu, press PRINT key to execute program or transfer to sub menu.

NOTE: Refer to the function keys available program and calibration menu.

Program and Calibration Menu, Function Key	Description
DATE-TIME/▲, PLU/▼	Selects a different menu
PRINT	Executes command or selects the submenu
X/ESC	Exits the Menu



Digit 1100 indicates Menu code. You should press PRINT key in prior menu to see sub menu screen as below.



You can also see the Program Menu screen by pressing the key continuously. It's quick way to execute program menu.



The sales transaction mode will work after scale's turning on. First to execute program menu, that menu code should have entered. And then you press the PRINT Key to execute program menu.



If you want to execute 1864 test chess print menu, just input chosen menu code.



You can see this screen for a while, after pressing PRINT key.

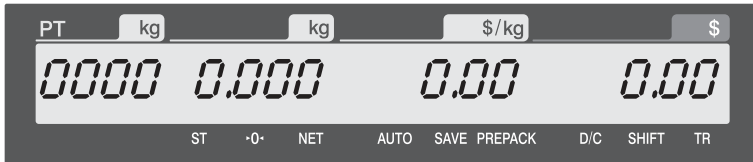

VFD display will return to sales mode after scale finish working.

2.1 PLU Programming

You can set 20 items for a PLU as below table and if you want to use expanded items(21~28), you can enable those items in menu code:1144.

No	Item	Description
	Department No	(1~99) Department No.
	PLU No	(1~999999) PLU No.
1	PLU Type	Select PLU type among By Weight(1), By Count(2) or By-PCS(3)
2	Name 1	Enter name 1 of item. Maximum 40 characters.
3	Name 2	Enter name 2 of item. Maximum 40 characters.
4	Name 3	Enter name 3 of item. Maximum 5 characters.
5	Group No.	Select group number. This value can be from 0 to 99.
6	Item code	(0~999999) Item code
7	Use Fixed Price Type	You can set wheter use Fixed Price or not
8	(Unit) Price	This value can be from 0 to 999999.
9	※Tare	You can enter tare weight manually. (By-weight PLU)
10	Packed Date	(0~999) This is added to the current date in order to be calculated.
11	Packed Time	(0~99) If you set it to 0, it is not printed
12	Sell-by Date	(0~999) This is expirations date that is numbered in days and added to the Packed On date in order to be calculated. If you set it to 0, it is not printed
13	Sell-by Time	(0~99) If you set it to 0, it is not printed
14	Ingredients No.	(0~100) Enter indirect ingredient no. It refers 1310 : MESSAGE If direct indredient is none, this indirect ingredient number is refered
15	Ingredients Text.	Direct ingredient text (Direct means PLU directly include ingredient text)
16	Label No.	(0~30,51~60) If it is not Settled, Label Formats are fixed by Grobal setting.
17	Barcode No.	(0~20) If it is not Settled, Label Formats are fixed by Grobal setting.
18	Produced Date	(0~999) This is subtracted to the current date in order to be calculated.
19	Sales Msg No.	(0~100) Enter sales message No. It refers 1240 : SALES MESSAGE
20	☆ Quantity Symbol ID	(0~8) Set symbol of PCS or Count

21	※ Unit Weight	Unit weight of Price (default 0 : unit price for 1kg)
No	Item	Description
22	Tare No	You can enter No. of tare data.
23	☆ Pieces	(0-99) Set the number for By-PCS PLU
24	Origin No.	(0-500) 0=Do not use origin.
25	Aux. Label No.	(0-99) (0=Do not use Label No.), This function prints aux. label as saved number of label number
26	Barcode2 No.	This value can be from 0 to 20
27	Special Price	It can be unit price by using Special key. (for future use)
28	※ Fixed Weight	The weight is fixed regardless of item

※ These items are only for By- Weight PLU.

☆ These items are only for By Count or By PCS PLU.

2.1.1 Create By-Weight PLU (Menu code 1120)

(MENU → PLU → New/Edit) (1120 + "MENU" key)

- ◆ You can press the SAVE key at anytime to save the current PLU data and if you want to exit without saving, press the ESC key.

1. Enter Department No. and PLU No.

- Department should be set previously

EX) Department No. = [1] Default
PLU No. : [1]

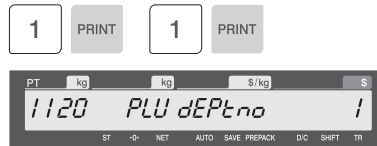

2. Select PLU 1 Type

1. By Weight
2. By Count
3. By PCS

EX) BY-Weight Item



By-Weight PLUs are priced as price-per-weight; for example, \$3.99/lb or \$1.99/kg.

3. Enter PLU 2 First Name

EX) "BEEF"



4. Enter PLU 3 2nd Name

EX) "SIRLOIN"



5. Enter PLU 4 3rd Name

EX) "001"

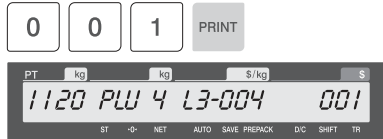

6. Select Group

• If there is no group for this PLU, enter "0".

EX) 1. Meat



7. Item Code

EX) Item Code = 1941



8. Use Fixed Price Type

The Price of an item is fixed.

• If you do not want to use, enter 0.

EX) Do not use Fixed Weight



9. Price

EX) Price = \$10.00



10. Tare

- You can use Tare Table,

EX) Tare Value = 100 g

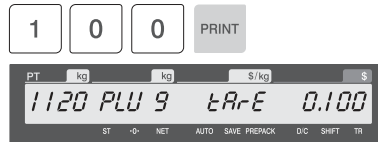

11. Packed Date

- This value can be from 0 to 999.

EX) 0 : Today 1 : Tomorrow
2 : Tomorrow +1



12. Packed Time

Current time + up to 99 hrs

EX) +1 hour

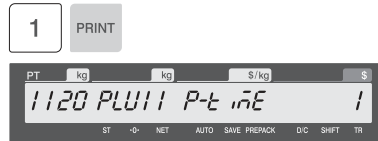

13. Sell By Date

- This value can be from 0 to 999.

EX) 0 : Do not print 1 : Packed date
2 : Packed date + 1



14. Sell By Time

- This value can be from 0 to 99.
- It's prohibited as default by 1870: PARAMETER.

EX) 0 : Do not print 1 : Packed date+ 1hour



15. Ingredient(Message) No

- Refer to 1310 : MESSAGE.
- If you do not want to use, enter “0”
- Even if this indirect Ingredient number is setted,
it doesn't work while direct Ingredient is active.



16. Ingredient Text

- If you want to use direct Ingredient message,
type character. Then indirect is disable.



17. Select Label Format

- If you enter “0”, standard grimal label format (menu code 1510) is used.
- To use another label form by each PLU,
refer to 1870: PARAMETER .



18. Barcode No.

- You can use barcode ID depending
on the setting of Menu code 1520

EX) Barcode Data Table 1



19. Produced Date

EX) 0 : Do not print 1 : Today
 2 : Yesterday



20. Sales Msg No.

- Refer to 1240 : SALES MESSAGE.
- If you do not want to use, enter “0”

EX) Sales Message 1



21. Qty Unit No.

- If you do not want to use, enter “0”
This field does not work to
By-Weight PLU.

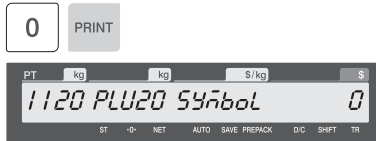

Please refer to menu code 1144: PLU EXPAND, to set the remaining plu data 21~28.

22. Unit Weight

- It set the Unit Weight of Price.
Default 0 : Price per 1kg



23. Tare No.

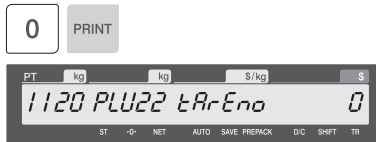

24. Pieces

- If you do not want to use, enter “0”
This field does not work to
By-Weight PLU



25. Origin No

- If you do not want to use origin,
enter “0”

EX) 49. China



26. Aux Label No

- It is a Number of another Label.



27. Barcode2 No.



28. Special Price (For future use)



29. Fixed Weight

The weight of an item is fixed.

- If you do not want to use, enter 0.

EX) Do not use Fixed Weight



30. SAVE PLU

- It's same function as pressing "SAVE".

EX)

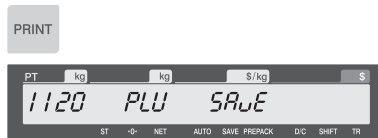

31. ERASE PLU

- Delete selected PLU.



2.1.2 Create By-Count PLU (Menu code 1120)

(MENU → 1. PLU → 2. New/Edit) (1120 + "MENU" key)

- ◆ You can press the SAVE key at anytime to save the current PLU data and if you want to exit without saving, press the ESC key.
- ◆ Please refer to 2.1.1 for PLU DATA setting which was not mentioned in this chapter 2.1.2.
It is recommended especially that you check up the PLU data No.20 and No.23.
That items are only for By Count PLU or By PCS PLU.

1. Enter Department No. and PLU No.

- Department should be set previously.

EX) Department No. = [1] Default
PLU No. : [2]

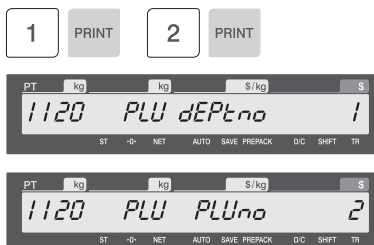

2. Select PLU 1 Type

1. By Weight
2. By Count
3. By PCS

EX) BY-Count Item



3. Enter PLU 2 First Name

EX) "PEAR"



4. Price

EX) Price = \$10.00

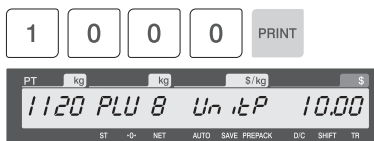

5. Qty Unit No.

- This field work to By-PCS PLU or By-Count PLU.

EX) Qty Unit No. 6



2.1.3 Create By-PCS PLU (Menu code 1120)

(MENU → 1. PLU → 2. New/Edit) (1120 + “MENU” key)

- ◆ You can press the SAVE key at anytime to save the current PLU data and if you want to exit without saving, press the ESC key.
 - * Please refer to 2.1.1 for PLU DATA setting which was not mentioned in this chapter 2.1.3.
- It is recommended especially that you check up the PLU data No.20 and No.23. That items are only for By Count PLU or By PCS PLU.

1. Enter Department No. and PLU No.

- Department should be set previously

EX) Department No. = [1] Default
 PLU No. : [3]

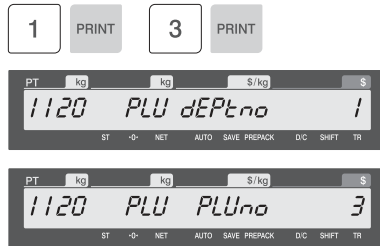

2. Select PLU 1 Type

1. By Weight
2. By Count
3. By PCS

EX) BY-PCS Item



3. Enter PLU 2 First Name

EX) “BEEF”



4. Price

EX) Price = \$10.00



5. Qty Unit No.

- This field work to By-PCS PLU or By-Count PLU.

EX) Qty Unit No. 6

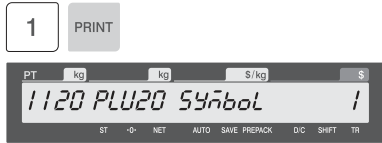

6. Pieces

- If you do not want to use, enter "0"
This field work to By-PCS PLU.

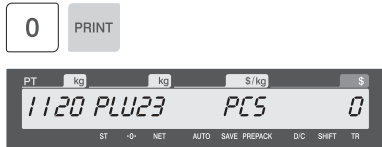

2.1.4 Editing PLU (Menu code 1120)

(MENU → 1. PLU → 2. New/Edit)

- ◆ You can edit PLU as PLU creating and you can press the SAVE key at anytime to save the current PLU data and if you want to exit without saving, press the ESC key.

2.1.5 Expand PLU (Menu code 1144)

(MENU → 1. PLU → List)

- ◆ If you select "YES", you will have 28 field of PLU.
But if you select "No", you will have only 20 field of PLU
- ◆ To select "YES", just press "1" key.
Or to select "No", just press "0" key on number keyboard.

2.1.6 Listing PLU (Menu code 1150)

(MENU → 1. PLU → 5. List)

1. Enter Department No.

- Enter department number that you wish to see

EX) Department No. 1

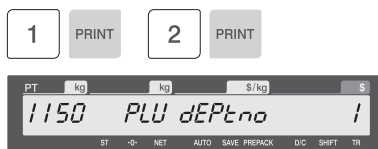

2. Enter PLU Range

EX) PLU 1~10 (start : 1, end : 10)

Scale print PLU labels in this range.

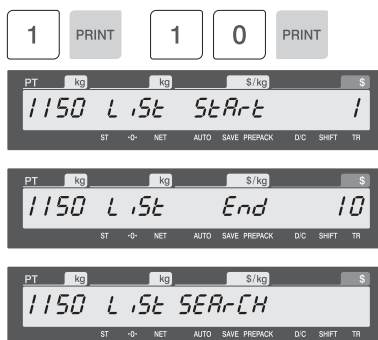

2.2 Programming PLU Data Table I

2.2.1 New/Edit Sales Message (Menu code 1240)

(MENU → 2. PLU Data Table I → Sales Message)

You can press the SAVE key at anytime to save the current data and if you want to exit without saving, press the ESC key.

1. Enter Message Number

- Message number is available 1 to 99

EX) Message No. = 1



2. Enter Message

EX) Message = THANK YOU



3. Save Message

- If you want to save & exit, press "Print" key.

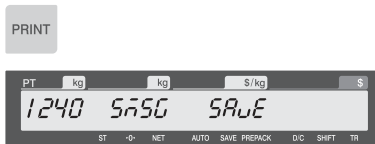

2.2.2 Origin (Menu code 1250)

(MENU → 2. PLU Data Table I → Origin)

You can use origin number when you create PLU.

- ◆ You can press the SAVE key at anytime to save the current data and if you want to exit without saving, press the ESC key.

1. Enter Origin No.

- Origin number is available 1 to 500

EX) Origin No = 10



2. Enter Origin

EX) Origin = KOREA



3. Save Menu

- If you want to save, press "PRINT" key.



2.2.3 Barcode (Menu code 1260)

(MENU → 2. PLU Data Table I → Barcode)

You can use barcode when you create PLU.

Barcode can be changed depending on the Global setting of barcode.

- ◆ You can press the SAVE key at anytime to save the current data and if you want to exit without saving, press the ESC key.

1. Enter Barcode No.

- This value can be from 1 to 99.

EX) Barcode No = 1



2. Barcode Type

- See below table.

EX) Barcode Type = 1. EAN-13



• Type of Barcode

No.	Type	Description
1	EAN-13	13digit
4	I20F5	2-24 digit
9	CODE128C	2-24 digit

3. Enter Barcode Form

- You can select from a list of Barcode types or you can create your own custom format
- Refer to below table.

EX) Barcode Form = 1. Change DDIIIIIPPPPC to GGIIIIIVPPPC

Press "PRINT".

Press ◀ 4 times then



Display that

Press Backspace key.



• Barcode format symbol

No	Symbol	Description
1	I	item code
2	N	PLU number
3	P	price
4	V	price check digit (It is created automatically)
5	U	unit price
6	W	weight
7	Q	quantity
8	D	department
9	G	group
10	C	total barcode check sum (It is created automatically)
11	B	transaction counter (serial number)

4. Save Menu

- If you want to save, press “PRINT” key.



2.2.4 Tare (Menu code 1270)

(MENU → 2. PLU Data Table I → Tare)

- ◆ You can press the SAVE key at anytime to save the current data and if you want to exit without saving, press the ESC key.

1. Enter Tare No.

- This value can be from 1 to 99..

EX) Tare No. = 1



2. Tare Weight

EX) Tare weight = 1.000 (kg),
Numeric Tare



3. Exit Menu

- If you want to exit, press “ESC” key.



2.2.5 List Unit Symbol (Menu code 1280)

(MENU → 2. PLU Data Table I → Unit Symbol)

- ◆ You can press the SAVE key at anytime to save the current data and if you want to exit without saving, press the ESC key.

1. Enter unit number

- This value can be from 1 to 8.

EX) Qty Unit No. = 2



2. Enter unit symbol

EX) Symbol = TH



- ※ If you want to enter special symbol, press the CHAR key and enter the code value. (See ASCII code table on chapter 4.4).

3. Save Menu

- If you want to save, press “PRINT” key.



2.3 Programming PLU Data Table II

2.3.1 Ingredient (Menu code 1310)

(MENU → 3. PLU Data Table II → Message)

- ◆ You can press the SAVE key at anytime to save the current data and if you want to exit without saving, press the ESC key.
- ◆ This indirect Ingredient can be printed or not depending on the direct Ingredient item of each PLU.
- ◆ Bear in mind that the direct Ingredient have priority over this indirect Ingredient.

1. Enter ingredient number.

- This value can be from 1 to 100.

EX) Ingredient number = 1



2. Enter ingredient

EX) Ingredient Line1 = SALT
Ingredient Line 2 = SUGAR

To print "SUGAR" on next line, enter
"↓" after "SALT".



3. Save Menu

- If you want to save, press
"PRINT" key.



4. Exit Menu

- If you want to exit, press
"ESC" key.



2.4 Speed Key Setting

This menu is to set “speed keys”, one-touch keys, for most frequently used PLUs to simply call up them. You can program up to 5 speed key set. Remember that there is a SHIFT key that allows you to double-use the Speed Keys. The Speed keys are numbered left-to-right and top-to-bottom.

☞ User can not assign the function key as speed keys.

2.4.1 Speed Key (Menu code 1160)

(MENU → PLU → Speed Key)

1. Speed Key Set No.

- Enter speed key set no

EX) Speed key set No. = 1



2. Select KEY PAD.

- Push the Key Pad . to assign speed key

EX) Using “A” button



3. PLU No.

- Enter PLU no. to assign speed key
- PLU should be belong to scale’s department.

EX) PLU 10 = BEEF



4. Exit Menu

- If you want to exit, press “ESC” key.



2.5 Programming Store Data

This chapter explains how to access, program STORE data table (Price Look Up) in CL5000J series.

2.5.1 Store Data (Menu code 1410)

(MENU → Store Data Table → Store)

This section shows how to create, edit, list and delete store, customer, and advertisement message data.

1. Enter the Store Name Edit menu.



2. Select the number and write the name.

EX) NAME=YANGJOO



3. Write the Telephone Number.

EX) NAME=YANGJOO



4. Write the Text.



5. Save Menu

- If you want to save, press “PRINT” key.



6. Exit Menu

- If you want to exit, press “ESC” key.



2.6 Programming Global Setting

2.6.1 Global Label Format (Menu code 1510)

(MENU → Global Setting → Label Format)

Label format #51~#60 are free formats that users may modify at their needs. Users may download one into the scale and set a specific free label format.

- ◆ You can press the SAVE key at anytime to save the current data and if you want to exit without saving, press the ESC key.

1. Set Global label No.

- Set PLU label number

EX) PLU Label No. = 51



2. Set Total label No.

- Set PLU label number

EX) PLU Label No. = 29 (default)



3. Set Invert(Reverse) label

- Set PLU label number.

EX) Non-Invert = 0
Invert = 1



4. Exit Menu

- If you want to exit, press "ESC" key.



2.6.2 Barcode Format (Menu code 1520)

(MENU → Global Setting → Barcode)

Global Barcode Setting provides all-in-one barcode setting by selecting nine different barcode options so that user does not need to save data for individual PLUs one by one. All related barcode data are selected and saved from PLU barcode data table user may already register.

- ◆ You can press the SAVE key at anytime to save the current data and if you want to exit without saving, press the ESC key.

1. Set Global barcode No.

- Set PLU label number

EX) PLU Barcode No. = 1



2. Exit Menu

- If you want to exit, press "ESC" key.



2.7 Printing Programming

This chapter explains how to set printing-related environments.

2.7.1 Printing (Menu code 1700)

(MENU → Print)

▶ PRINT Submenu

No	Sub-menus	Description
1	Select Label Item	Select item(s) which is(are) not printed on label.
3	Print Hardware	Set the label type and sensor of printer

2.7.2 Inhibit(Select) Printing Items(Menu code 1710)

(MENU → Print → ITEM)

If you set any of the items to 0, then they will NOT print on any labels regardless of the label format.

- ▶ You can press the SAVE key at anytime to save the current data and if you want to exit without saving, press the ESC key.

If you do not want to print, enter 0(Reset),
if you want to print, enter 1(Set).

No	Description
1	Serial Number
2	Packed Date
3	Packed Time
4	Sell By Date
5	Sell By Time
6	Store Name / Telephone Number / Text
7	PLU Number

2.7.3 Printer Hardware (Menu code 1730)

(MENU → Print → Printer Hardware)

This section is to explain how to set printing H/W environments in the following table.

► Printer Hardware Sub-Menu

No	Sub-menus	Description
1	Label Size	Lable mode " <u>Height(40)</u> * () are default value.
2	Sensor Calibration	You can mearsure "Gap" & "Peel" . And print out them. Also you can test Sensor & Motor.
3	Sensor & Motor	Setting Peel-off sensor.
4	Print Intensity	Set the extent of intensity of label printed.
5	Adjust Feed Length	Set adjusting values of feed length. This value can be from "0" to "400"
6	Label Pre-print	You can set preprint length.
7	Printer Initialize	You can reset printer.

2.7.4 Label Size (Menu code 1732)

(MENU → Print → Printer Hardware → Label Size)

You can input "Height" of label manually. (30~80mm)

Default label size is 40mm.

If you want to use different size label roll, make sure that set up this menu.

2.7.5 Sensor Calibration (Menu code 1733)

(MENU → Print → Printer Hardware → Sensor Calibration)

This mode will automatically feed the label several times to calculate the measurement.

The average data of "Gap" & "Peel" are printed out, and displayed on screen.

It is best way to arrange label roll's position automatically.

This menu help you to adapt all other print hadware setting, for example their intensity, feed length, preprinting.

2.7.6 Peel Sensor (Menu code 1734)

(MENU → Print → Printer Hardware → Peel)

You can select [Y], [N] for "ACTIVE PEEL-OFF".
Selecting [Y], printer didn't work until you take off former printed label.
But [N], when you press print key, label was print out by compulsion.

2.7.7 Print Intensity (Menu code 1735)

(MENU → Print → Printer Hardware → Print Intensity)

You can enter any value from "0" to "4" set the tension of label.
The 2 is default value.

2.7.8 Adjust Feed Length (Menu code 1736)

(MENU → Print → Printer Hardware → Adjust Feed Length)

User may enter any value of the feed alignment from "0" to "400".
You can adjust the printing position detail with this menu.

* 1pixel = 0.125mm , 8pixel = 1mm

2.7.9 Label Preprint (Menu code 1737)

(MENU → Print → Printer Hardware → Label Preprint)

User may select Preprint mode and any value of the preprint length from "0" to "10".
It controls the length that label is pushed out.

2.7.10 Printer Initialize (Menu code 1738)

(MENU → Print → Printer Hardware → Printer Initialize)

Initialize printer to factory setting.

2.8 Programming Scale Configuration

2.8.1 Department (Menu code 1830)

(MENU → Scale Config → Department)

This section shows how to select current department where scale is being used. User can use (call up) PLUs only for current department selected in sales mode.

For example, if current department selected is 2(GROCERY) user can call up items registered only in 2(GROCERY) department. If user would like to use PLUs registered in other department than current department he/she should change scale's department setting.

Store No. represents Store Name (or branch number) on label printed.

1. Select "DEPARTMENT No." and "STORE ID".

EX) DEPARTMENT No.= 2 (Grocery)



2. STORE No.= 1 (Branch #1)



3. Write the Speed Key Set Number



2.8.2 Date & Time (Menu code 1840)

(MENU → Scale Config → Date/Time)

This section is to set scale's DATE & TIME appropriately.

You can use     and number pad.

Year

2.8.3 Change Password (Menu code 1852)

(MENU → Scale Config → Change Password)

2.8.4 Display Test (Menu code 1861)

(MENU → Scale Config → Test → Display)

To test the display, press "PRINT" on Test menu screen. It automatically tests it. User may exit from testing, using "X/ESC" key.

2.8.5 A/D Test (Menu code 1862)

(MENU → Scale Config → Test → 2. A/D)

To test the A/D, press "PRINT" on Test menu screen.

To set zero press "ZERO" 

User may exit from this menu, using "X/ESC" key

2.8.6 Keyboard Test (Menu code 1863)

(MENU → Scale Config → Test → Keyboard)

To test keyboard, press "PRINT" on Test menu screen.

To exit keyboard test, press "ESC" two times.

2.8.7 Chess Printer Test (Menu code 1864)

(MENU → Scale Config → Test → Chess Print)

Press "PRINT" key to test printing a label.

User may exit from this menu, using "X/ESC" key.

2.8.8 Printer Sensor Test (Menu code 1865)

(MENU → Scale Config → Test → Printer Sensor)

User may exit from this menu, using "X/ESC" key.



2.8.9 Scale Parameter (Menu code 1870)

(MENU → Scale Config → Printer Hardware → Scale Parameter)

You can set scale's environment by changing Parameter Values.

But you must be careful how you deal it.
The Parameters are concerned with Factory Setting.
So your missing might raise some problems.

2.8.10 Clear Memory (Menu code 1890)

(MENU → Scale Config → Clear Memory)

2.8.10.1 Clear PLU (Menu code 1891)

(MENU → Scale Config → Clear Memory → PLU)

Clear all PLU data. This time discount data is will be cleared.



2.8.10.2 Clear Table1 (Menu code 1892)

(MENU → Scale Config → Clear Memory → Table1)

Clear all Table1 date(Except PLU/discount data).

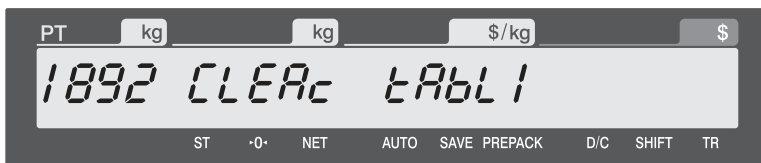

2.8.10.3 Clear Table2 (Menu code 1893)

(MENU → Scale Config → Clear Memory → Table2)

Clear all Table2 date(Except PLU/discount data).



2.8.10.4 Clear ALL (Menu code 1894)

(MENU → Scale Config → Clear Memory → Table2)



NOTE: Clear PLU, Table1, Table2 and Shop data
Symbols and Speed key is initialized

2.9 Report

2.9.1 Report Menu (Menu code 1600)

(MENU → Report)



No	Sub-menus	Description
1	Report Print	Print and display sales data
2	Clear All	Clear all reports of period 1 and 2

2.9.2 Print Report (Menu code 1610)

(MENU → Report → Print Report)

There are 3 detailed reports.

No	Sub-menus	Description
1	Scale	Print and display scale sales report
2	PLU	Print and display PLU sales report
3	Misc. PLU	Print and display misc. PLU sales report
4	Group	Print and display group sales report
5	Department	Print and display department sales report
6	Hourly	Print and display hourly sales report

2.9.3 Scale Sales Report (Menu code 1611)

(MENU → Report → Print Report → Scale)

Menu code 1611 print out all information of sales. It includes total count, total price, amount of prepack price, etc.

2.9.4 PLU Report (Menu code 1612)

(MENU → Report → Print Report → PLU Report)

Press "Print" key PLU report menu screen.

PRINT



Enter the number of Depmnt and Press "Print" key.

1

PRINT



Enter the number of PLU and Press "Print" key.

1

PRINT



This menu print out information of each PLU data.

2.9.5 Miscellaneous PLU Report (Menu code 1613)

(MENU → Report → Print Report → MISC. PLU)

Menu code 1613 print out rest information of sales. It maybe includes some price that didn't saved in PLU. So our direct sales price will be printed.

2.9.6 Group Report (Menu code 1614)

(MENU → Report → Print Report → Group)

Press "Print" key PLU report menu screen.

PRINT



Enter the number of Group and Press "Print" key.



This menu print out information of each PLU Group data.

2.9.7 Deptment Report (Menu code 1615)

(MENU → Report → Print Report → Department)

Press "Print" key PLU report menu screen.



Enter the number of Department and Press "Print" key.



This menu print out information of each Department data.

2.9.8 Hourly Report (Menu code 1616)

(MENU → Report → Print Report → Department)

Press "Print" key PLU report menu screen.



Enter the number of Hours and Press "Print" key.



This menu print out information of each data within a day periode of time.

2.9.9 Clear All Report (Menu code 1650)

(MENU → Report → Clear All)

You can delete all of report. If you delete all, then scale will create new report data. When you print out report later, updated report will be printed

2.10 Communication

2.10.1 Communication (Menu code 1900)

(MENU → Communication)

1. Feature

You can control scale with PC or any computing environment, to do work such as data table up/down loading, deleting.

2. Pre-caution

Set each Scale ID different (for individual scale management) Especially for report feature in CL-Works needs individual scale ID to locate report data.

3. Communication concept diagram

Following picture describes how to set-up the network between scale and PC

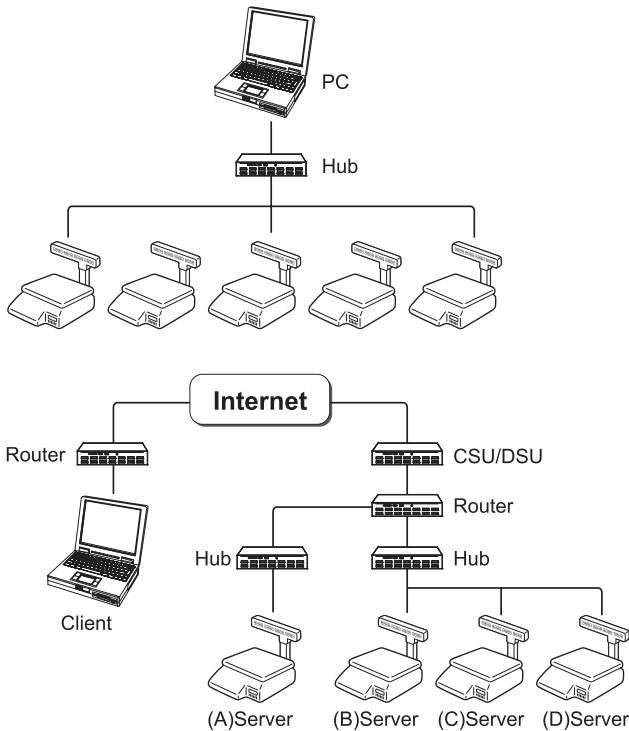

(Internet communication with PC and Scale)

If you know the scale's IP address and your PC has the registered PC program, you can access scale individually or all together to monitor report and update PLUs.

NOTE: If you have set HUB (Bridge, Repeater, etc...) use PC manager to search correspond scales

For setting figure 1, 2 network setup; you must input individual IP address for connection test.

Figure 3 show that scales are connected via internet; when you know the scale IP address, you can access any other network scale.

4. Before setting the network

- Each scale needs fixed IP address.
- Do not use DHCP without prior notice to CAS. If so CL-Works will not able to retract the right scale because access IP address will change constantly.
- You need to assign proper IP, Gateway, Subnet Mask address from webmaster.
NOTE: These 3 elements are basic information to operate internet / intranet.
Please get prior training on internet network; otherwise recommend to get advice from network management person.
- You can set scale up to 99 for PC control networking.

2.10.2 Network Setting (Menu code 1910)

(MENU → Communication → Network Setting)

No	Sub-menus	Description
1	DHCP	Dynamic Host Configuration Protocol
2	IP	Setup IP add, subnet, gateway and Port Number..
3	RS232C	Setting of the b-rate.

2.10.3 DHCP (Menu code 1912)

(MENU → Communication → Network Setting → DHCP)

Setting Dynamic Host Configuration Protocol



This mode for Automatic Private IP Addressing.
Your network has stable DHCP sever, It is very useful mode.

Change setting with   keys.

2.10.4 IP (Menu code 1913)

(MENU → Communication → Network Setting → IP)

Setting IP and Port



Set IP address and Port

Scale need to have own TCP/IP

NOTE: Recommend to get this information from authorized network management person.

If scale does not connected to internet or any other POS system, you can set initial IP address (192.168.1.1) and Gateway (192.168.1.1), Subnet Mask (255.255.255.0)

If connecting only 2 scale just set different IP address. Therefore set #1 for 192.168.1.1, and other 192.168.1.2
Set Gateway 192.168.1.1
Leave Port as factory setting.

If IP address changes scale will reboot

2.10.5 RS232C Setting (Menu code 1915)

(MENU → Communication → Network Setting → B-RAT)

No.	Baud Rate
0	9600
1	19200
2	38400
3	57600

3. SALES OPERATION

3.1 Basic Operation

This chapter explains basic operation of scale, such as how to set zero, tare, call up a PLU and override unit price in CL5000J series. In order to make sales transaction user should access REGISTRATION mode.

- How to access REGISTRATION MODE: Turn ON the scale.



3.2 Zero

You can use the ZERO key to correct for a deviation from zero as long as there are no PLUs or MISC PLUs called-up. The weight can sometimes drift from zero due to debris on the platter, leaving objects on the platter for excessive periods of time, or other environmental factors. To correct this, remove everything from the platter and press the ZERO key when the stable indicator “▼” is on. Below is a possible zero drifted state that should be corrected by simply pressing the ZERO key.

- ① EX) Initial weight displayed → 0.002.

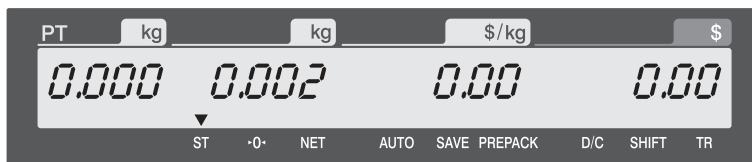

- ② Press “ZERO” key to set initial zero.

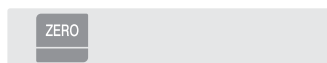



3.3 Tare

You can enter tare weights as long as there are no PLUs or MISC PLUs called-up. If you need to temporarily override a PLU's tare weight, you must enter the tare weight first and then call-up that PLU. There are two ways to enter a tare weight and both ways will only work if there is no PLU or MISC PLU called-up.

3.3.1 Manual Tare Entry

- ① Enter a tare weight manually by pressing the numeric keys EX) 150 g



- ② Press "TARE" key.

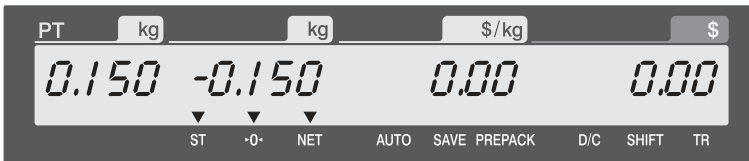
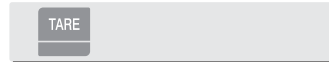

3.3.2 Weighed Tare Entry

- ① Place the empty container on the platter making sure that the weight is stable EX) 0.15 kg



② Press “TARE” key.

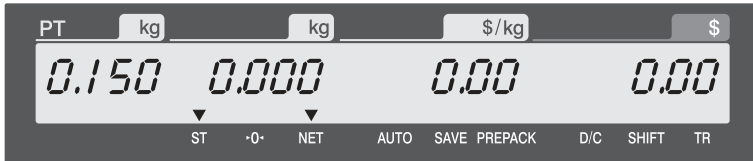
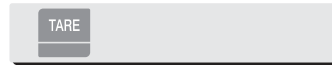

3.3.3 How to Clear Tare

① Remove the item from the platter



② Press “TARE” key again.



3.3.4 Preset Tare

① Call up a PLU including tare (weight of container).

EX) PLU #3 s tare =150 g

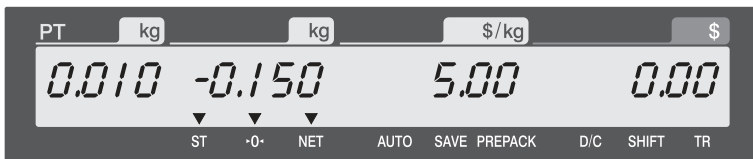

- ② Clear PLU#3, then tare is also automatically cleared.

3.3.5 Successive Tare

- ① Enter tare (weight of container) using numeric keys.
EX) 150 g

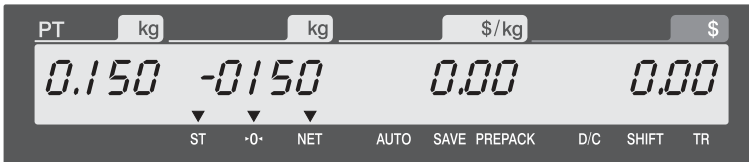

- ② Enter the weight of container using numeric keys.
EX) 200 g

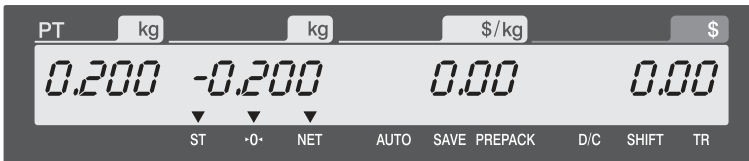

- ③ Press "TARE key after removing item and container from the platter.

3.3.6 Tare Override

- ① Call up a PLU including tare (weight of container).
EX) PLU #3 s tare = 100 g

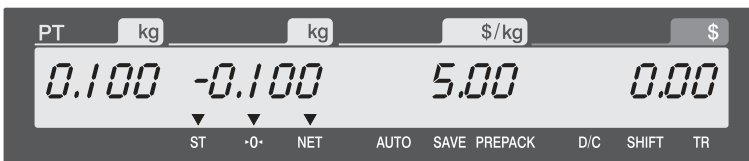

- ② Place the container (Weight of container must be greater than weight data input) for TARE OVERRIDE.

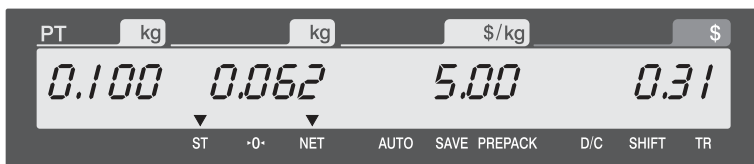

- ③ Pressing “TARE” key overrides current PLU tare (weight of container) and the weight becomes “0”.

3.4 Calling Up a PLU

There are two ways to call up a PLU by using numeric key and preset key.

3.4.1 Using Numeric Key

- ① Enter PLU number by using numeric keys and press “PLU” key.
EX) PLU No. 15



3.4.2 Using Speed Key

To call-up PLU number 79, and you programmed Speed key #5 to be PLU number 79, then you need to press the following key: Speed key #5.

Note: You have to set Speed key in program mode (Menu 1160 on chapter 2.6.1)

- ① Press a speed key (which is save as a PLU).
EX) PLU #79=Apple, Speed key #5



3.5 Override (FOR key)

The OVERRIDE key is used to temporarily change the pricing of priced PLUs.

- ☞ If you set program menu 1873(Save unit price change), changed priced is saved after printing a label.
- ☞ If Para 534 : Default UnitWeight is different from unit weight of PLU, "Multiple Unit PLU" message can be occurred.

3.5.1 By-Weight PLU

- PLU# 1.MEAT (PLU Type : By weight, Unit Price : 1.99\$).

- ① Press OVERRIDE key.

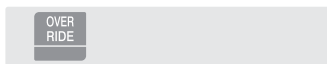

- ② Enter new unit price.



- ③ Press PRINT key to print label.

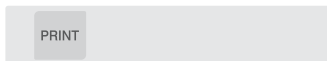

3.5.2 By-Count PLU

- PLU# 2.APPLE (PLU Type : By count, Unit Price : 1.00\$).

① Press OVERRIDE key.

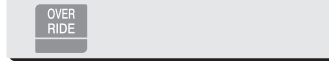

② Enter QUANTITY and press FOR key.



③ Enter new unit price.



④ Enter QUANTITY and press FOR key.

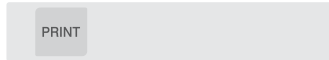

3.5.3 By-PCS PLU

- PLU# 3.Eggs (PLU Type : By PCS, Pieces : 3, Unit Price : 30.00\$).

① Press OVERRIDE key.

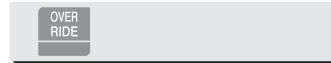

② Enter QUANTITY and press FOR key.



③ Enter PIECES and press FOR key



④ Enter new unit price.

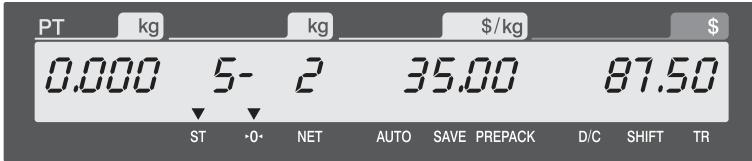

⑤ Press PRINT key to print label.

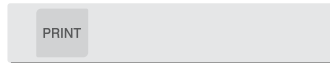

3.6 Sales Operation

3.6.1 Weighed Item Operation

EXAMPLE:

- PLU No : 29, PLU Name: ONION, PLU type : by weight, Unit Price : 1.50\$,
- Sales Weight =1.0kg

① Press Speed key to call up a PLU.

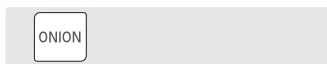

② Place the item(s) on the platter.



③ Press "PRINT" key to print a label and complete current transaction.
This transaction(s) is saved in the sales record.



- ④ Remove the item(s) from the platter.



* Total Price= Sales weight X Unit price

Note: - In "SAVE" & "Prepack" mode the PLU is not automatically cleared when you remove the item from the platter.

- If you set "PLU clr Aft sale(WT.OnTray)" to "Y" in Menu 1873, PLU is cleared even though you do not remove the item from the platter. (See chapter 2.14.21 for menu 1873)

3.6.2 By Count Item

EXAMPLE:

- PLU No : 31, PLU Name: MANGO, PLU type = By-Count, Unit Price: 1.99\$,
- Sales 20 pieces.

- ① Press numeric key(s) to call up a PLU.

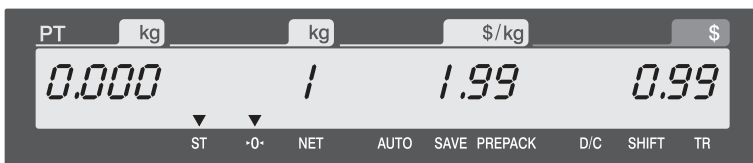

- User may call up a PLU by pressing speed key or numeric key. Please refer to chapter 3.4 for details.

- ② Enter the number of pieces.
EX) 20 pieces.



- ③ Press “PRINT” key to print a label and complete current transaction.
This transaction(s) is saved in the sales record.



* Total Price= Piece(s) X Unit price

Note: - In “SAVE” & “Prepack” mode, the PLU called up is not automatically cleared when you remove the item from the platter.

3.6.3 By PCS Item

EXAMPLE:

- PLU No : 30, PLU Name: ORANGE, PLU type = By PCS, PIECES: 5,
Unit Price : 1.99\$
- Sales = 20 pieces. [QUANTITY item]

- ① Press numeric key(s) to call up a PLU.



- User may call up a PLU by pressing speed key or numeric key. Please refer to page 143 for details.

- ② Enter QUANTITY [the number of Pieces].
EX) 20 pieces.



③ Press “PRINT” key to print a label and complete current transaction.
This transaction(s) is saved in the sales record.



* Total Price= QUANTITY X [Unit price / PIECES]

Note: - In “SAVE” & “Prepack” mode the PLU is not automatically cleared when you remove the item from the platter.

3.7 Add-Up Transaction

If you press the ADD key instead of the PRINT key, you will initiate the ADD-UP process. You can ADD-UP 399 items maximum.

EXAMPLE 2:

- PLU# 32=SIRLOIN, PLU Type = By-Weight, Unit Price=20.00,
- PLU# 35=T-bone Steak, PLU Type = By-PCS, Pieces=3, Unit Price=6.00

① Call up a PLU and place item on the platter.

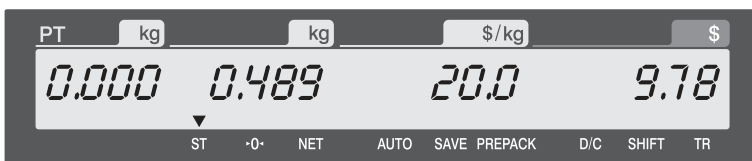

② Press ADD key. PLU is cleared automatically.

You will see the display as below. Remove item from the platter.

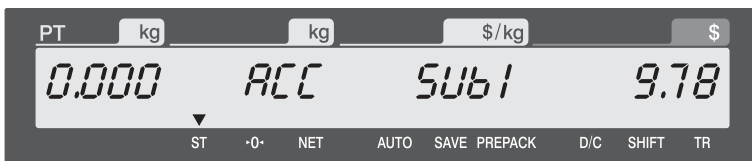
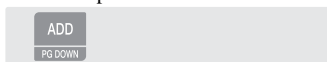

③ Call up a PLU. and place item on the platter

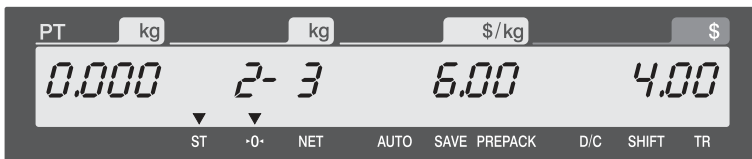

④ Press ADD key. PLU is cleared automatically. You will see the display as below.

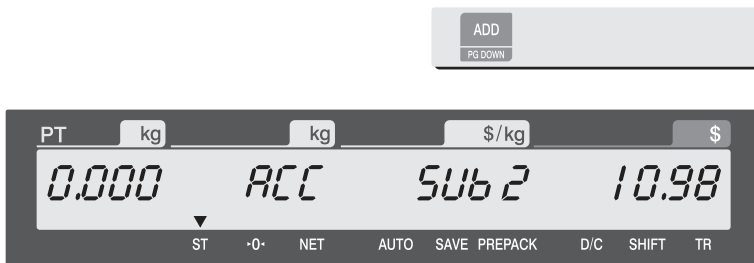

⑤ To complete the sale, press the PRINT key.
(To repeat the ADD-UP process, press the ESC key.)

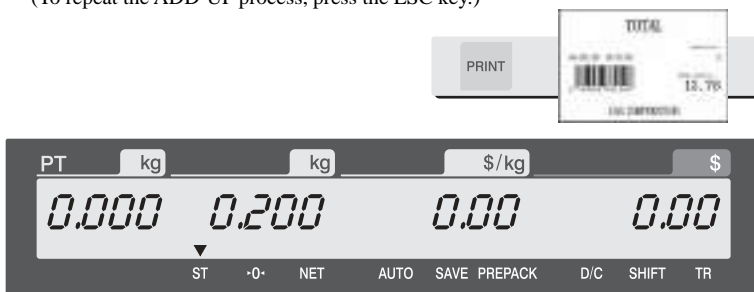

Note:

- You can press the VOID key to undo the transaction. (See chapter 3.10).
- If you set "Print Item Label" to "Y" in menu 1750 of program mode, label will be printed whenever you press the ADD key. (See chapter 2.13.3)
- Even though you turn off the scale before printing a grand total label, add-up data is not cleared.

3.8 Void

You can press the VOID key to undo transaction in add-up process or floating clerk operation.

Assumption) You sold several items

◆ If there is some PLU and some price to void

① Press ST/TTL key

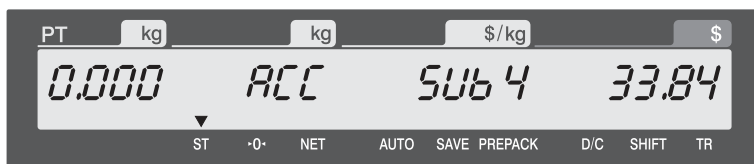
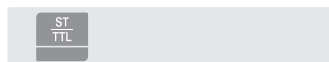

② Press VOID key then last sale is cleared.

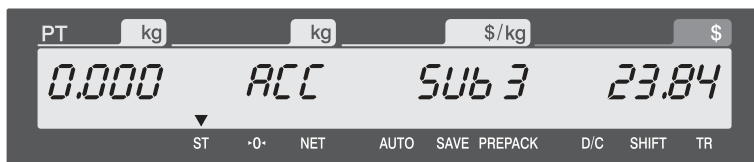

3.9 Return

The RETURN key is used to delete erroneous sale transactions. You can use the RETURN key to undo erroneous sales transactions like pressing the PRINT key inadvertently, selecting and printing the wrong PLU, an inadvertent Auto-Print in Pre-Pack mode, or perhaps adjusting the sales totals for a damaged or ruined package. Whatever the reason, the RETURN function will decrement returned PLU's transaction counter and sales totals by the specified amount.

You need to call-up the PLU that you wish to return by either pressing its corresponding speed key or typing its number.

◆ When the price is zero,

- 0) By weight PLU : You need to enter the total price and weight that was printed on the return PLU s label
- 1) By count PLU: You need to enter the total price and quantity that was printed on the return PLU s label

◆ When the price is higher than zero,
Return function is performed by pressing RETURN key

3.10 Prepack Key

When the scale is in Pre-Pack mode, it prints labels automatically. When it is in MANUAL mode, you must press the PRINT key (or ADD key) to get a label. In Pre-Pack mode, you cannot select AUTO mode. Pre-Pack works like AUTO and SAVE mode except that the weight does not need to return to zero for every auto-print.

Pre-pack mode is very useful in back-room applications. This mode increases productivity by not requiring the user to press the PRINT key for every package. Instead the user can concentrate on weighing, wrapping, and labeling.

This function is only available for by-weight PLU.

EXAMPLE:

Speed key #1= Onion Unit price=1.50, Sales Weight=1.0kg,

- ① Press PREPACK key and call up a PLU



* User may call up a PLU by pressing speed key or numeric key. Please refer to Menu code 1160.

- ② Place the item(s) on the platter.



③ Label is issued automatically.



Note: If the scale is in Prepack mode then it will always auto-print if the Total price is greater than 0.00 and:

3.11 Direct Discount

If there is no discount information in PLU, you can use this function.

3.11.1 % Discount Price Key

- ① Place item on the platter and Call up a PLU(#1.APPLE) and press “%Discount” key
- ②



- ② Enter % amount to discount and press PRINT key
Ex) 20%



- ③ Press PRINT key..

Note: - To use % DISCOUNT key, you have to set this key in menu 1880 of program mode. (See chapter 2.14.22)

4. Appendix

4.1 Label Format

There are fixed label format and user label format

	Fixed Label Format	User Label Format
No.	1~30	51-60
Quantity	30	10
Method	Built in CL5000J	Download from PC
Features	You cannot edit format.	Using the PC program, you can program format numbers 51 to 60.

► Fixed Label Format

No	Name	Width (mm)	Height (mm)	No	Name	Width (mm)	Height (mm)
1	IS6030-00001	60	30	24	IS5068-00024	50	68
2	IS6030-00002	60	30	25	IS5068-00025	50	68
3	IS6030-00003	60	30	26	IS5068-00026	50	68
4	IS5635-00004	56	35	27	IS6063-00027	60	63
5	IS5635-00005	56	35	28	IS6063-00028	60	63
6	IS5635-00006	56	35	29	IC6040-00029	60	40
7	IS6040-00007	60	40	30	IC6040-00030	60	40
8	IS6040-00008	60	40				
9	IS6040-00009	60	40				
10	IS6040-00010	60	40				
11	IS6040-00011	60	40				
12	IS6040-00012	60	40				
13	IS5040-00013	50	40				
14	IS5040-00014	50	40				
15	IS5040-00015	50	40				
16	IS5653-00016	56	53				
17	IS5653-00017	56	53				
18	IS5054-00018	50	54				
19	IS5054-00019	50	54				
20	IS6051-00020	60	51				
21	IS6051-00021	60	51				
22	IS6060-00022	60	60				
23	IS6060-00023	60	60				

1	2	3
 <p>SWEETENED CONDENSED MILK (VERY SWEET and STICKY) TWEED 1.00 1.00 1.25 2.00 38.91 TOTAL PRICE CAG CORPORATION 1487-15100 15000 M-15100 15100 15100 15100</p>	 <p>SWEETENED CONDENSED MILK TWEED 1.00 1.00 1.25 2.00 38.91 TOTAL PRICE CAG CORPORATION 1487-15100 15000 M-15100 15100 15100 15100</p>	 <p>SWEETENED CONDENSED MILK TWEED 1.00 1.00 1.25 2.00 38.91 TOTAL PRICE CAG CORPORATION 1487-15100 15000 M-15100 15100 15100 15100</p>
4	5	6
 <p>SWEETENED CONDENSED MILK (VERY SWEET and STICKY) TWEED 1.00 1.00 1.25 2.00 38.91 TOTAL PRICE CAG CORPORATION 1487-15100 15000 M-15100 15100 15100 15100</p>	 <p>SWEETENED CONDENSED MILK TWEED 1.00 1.00 1.25 2.00 38.91 TOTAL PRICE CAG CORPORATION 1487-15100 15000 M-15100 15100 15100 15100</p>	 <p>SWEETENED CONDENSED MILK TWEED 1.00 1.00 1.25 2.00 38.91 TOTAL PRICE CAG CORPORATION 1487-15100 15000 M-15100 15100 15100 15100</p>
7	8	9
 <p>SWEETENED CONDENSED MILK (VERY SWEET and STICKY) TWEED 1.00 1.00 1.25 2.00 38.91 TOTAL PRICE CAG CORPORATION 1487-15100 15000 M-15100 15100 15100 15100</p>	 <p>SWEETENED CONDENSED MILK TWEED 1.00 1.00 1.25 2.00 38.91 TOTAL PRICE CAG CORPORATION 1487-15100 15000 M-15100 15100 15100 15100</p>	 <p>SWEETENED CONDENSED MILK TWEED 1.00 1.00 1.25 2.00 38.91 TOTAL PRICE CAG CORPORATION 1487-15100 15000 M-15100 15100 15100 15100</p>
10	11	12
 <p>SWEETENED CONDENSED MILK (VERY SWEET and STICKY) TWEED 1.00 1.00 1.25 2.00 38.91 TOTAL PRICE CAG CORPORATION 1487-15100 15000 M-15100 15100 15100 15100</p>	 <p>SWEETENED CONDENSED MILK TWEED 1.00 1.00 1.25 2.00 38.91 TOTAL PRICE CAG CORPORATION 1487-15100 15000 M-15100 15100 15100 15100</p>	 <p>SWEETENED CONDENSED MILK TWEED 1.00 1.00 1.25 2.00 38.91 TOTAL PRICE CAG CORPORATION 1487-15100 15000 M-15100 15100 15100 15100</p>

25	26	27
<p>SWEETENED CONDENSED</p> <p>Made with 100% real milk of the white variety and sugar added. The amount of sugar added makes up 50% of the sweetened condensed milk volume. It is very thick and is added to a variety of other products, such as soups and puddings. Sweetened condensed milk is used in a variety of other products and is added to a variety of other products. It is also known as 14 to 14 milk.</p> <p>1.216 32.00 38.91</p> <p>SKU: 01000000000000 MFG: Chicago-1</p>	<p>SWEETENED CONDENSED (VERY SWEET and STICKY)</p> <p>Made with 100% real milk of the white variety and sugar added. The amount of sugar added makes up 50% of the sweetened condensed milk volume. It is very thick and is added to a variety of other products, such as soups and puddings. Sweetened condensed milk is used in a variety of other products and is added to a variety of other products. It is also known as 14 to 14 milk.</p> <p>1.216 32.00 38.91</p> <p>SKU: 01000000000000 MFG: Chicago-1</p>	<p>SWEETENED CONDENSED MILK (VERY SWEET and STICKY)</p> <p>Made with 100% real milk of the white variety and sugar added. The amount of sugar added makes up 50% of the sweetened condensed milk volume. It is very thick and is added to a variety of other products, such as soups and puddings. Sweetened condensed milk is used in a variety of other products and is added to a variety of other products. It is also known as 14 to 14 milk.</p> <p>1.216 32.00 38.91</p> <p>SKU: 01000000000000 MFG: Chicago-1</p>
28	29	30
<p>SWEETENED CONDENSED MILK</p> <p>Made with 100% real milk of the white variety and sugar added. The amount of sugar added makes up 50% of the sweetened condensed milk volume. It is very thick and is added to a variety of other products, such as soups and puddings. Sweetened condensed milk is used in a variety of other products and is added to a variety of other products. It is also known as 14 to 14 milk.</p> <p>1.216 32.00 38.91</p> <p>SKU: 01000000000000 MFG: Chicago-1</p>	<p>TOTAL</p> <p>200.96</p> <p>SKU: 01000000000000 MFG: Chicago-1</p> <p>*Total Label</p>	<p>SWEETENED CONDENSED MILK (VERY SWEET and STICKY)</p> <p>Made with 100% real milk of the white variety and sugar added. The amount of sugar added makes up 50% of the sweetened condensed milk volume. It is very thick and is added to a variety of other products, such as soups and puddings. Sweetened condensed milk is used in a variety of other products and is added to a variety of other products. It is also known as 14 to 14 milk.</p> <p>1.216 32.00 38.91</p> <p>SKU: 01000000000000 MFG: Chicago-1</p>

4.2 Fixed Label Format Sample

► (1) Label sample 1

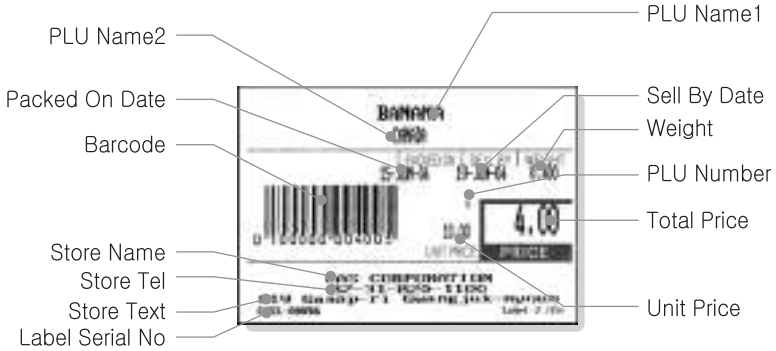

► (2) Label sample 2

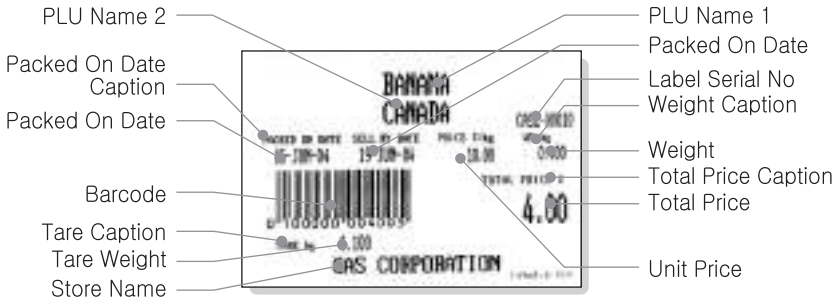

4.3 Label Field

Label Format has several fields and each field has own ID.

Item label print the information of each PLU sale and Total label print the information of grand total of PLUs.

4.3.1 Item Label Field

No	Item	Field ID	Description
1	Department Name	1	Print department name.
2	Department No	115	Print department number.
3	Group No	9	Print group number
4	PLU No	2	Print PLU number
6	PLU Name1	29	Print PLU name1,2 and 3. Depending on the setting of MENU 1862 "Print origin for comm. line", Origin can be printed.
7	PLU Name2	30	
8	PLU Name3	31	
9	Item Code	11	Print item code
10	Prefix	3	Print prefix
11	Unit Weight	5	Print unit weight
14	Tare Weight	13	Print tare weight.
15	Pieces	14	Print Piece for By-Pcs PLU
16	Qty Symbol	15	Print symbol of Quantity.
17	Sell By Date	16	Print sell by date.
18	Sell By Time	17	Print sell by time. If sell by time is 0, it is not printed
19	Packed On Date	18	Print packed on date.
20	Packed On Time	19	Print packed on time
21	Produced Date	20	Print produced date. If produced date is 0, it is not printed
24	Origin	55	Print origin
25	Ingredient	25	Print ingredient
26	Sales Message	90	Print sales message
29	Percent Tare	24	Print percent tare. It is printed with %.
30	Percent Tare Limit	23	Print percent tare limit. It is printed with %.
31	Weight	101	Print weight when it is not applied Markdown (By-Weight PLU)
34	Quantity	112	Print quantity when it is not applied Markdown (By-Count/By-Pcs PLU)

37	Unit Price	6	Print unit price when it is not applied Markdown
40	Total Price	102	Print total price when it is not applied Markdown
44	Label Serial	135	Print label serial number
45	Store Name	105	Print store name
46	Store Tel	138	Print Telephone numer of store
47	Store Text	139	Print information of store.
52	Scale Number	137	Print scale number

4.4 ASCII Code Table

Microsoft Window Codepage 1252

	00	01	02	03	04	05	06	07	08	09	0A	0B	0C	0D	0E	0F
00	NUL 0000	STX 0001	SOT 0002	ETX 0003	EOT 0004	ENQ 0005	ACK 0006	BEL 0007	BS 0008	HT 0009	LF 000A	VT 000B	FF 000C	CR 000D	SO 000E	SI 000F
10	DLE 0010	DC1 0011	DC2 0012	DC3 0013	DC4 0014	NAK 0015	SYN 0016	ETB 0017	CAN 0018	EM 0019	SUB 001A	ESC 001B	FS 001C	GS 001D	RS 001E	US 001F
20	SP 0020	!	"	#	\$	%	&	'	(*	+	,	-	.	/	
30	0	1	2	3	4	5	6	7	8	9	:	;	<	=	>	?
40	@	A	B	C	D	E	F	G	H	I	J	K	L	M	N	O
50	P	Q	R	S	T	U	V	W	X	Y	Z	[\]	^	_
60	`	a	b	c	d	e	f	g	h	i	j	k	l	m	n	o
70	p	q	r	s	t	u	v	w	x	y	z	{		}	~	DEL 007F
80	€ 20AC	•	/	f	"	•	†	‡	~	%	Š	<	€	•	Ž	•
90	•	•	•	•	•	•	•	•	•	•	•	•	•	•	•	•
A0	NBSP 00A0	¡	¢	£	¤	¥	¦	§	¨	©	ª	«	¬	®	¯	°
B0	°	±	²	³	´	µ	¶	·	¸	¹	º	»	¼	½	¾	¿
C0	À	Á	Â	Ã	Ä	Å	Æ	Ç	È	É	Ê	Ë	Ì	Í	Î	Ï
D0	Ð	Ñ	Ò	Ó	Ô	Õ	Ö	×	Ø	Ù	Ú	Û	Ü	Ý	Þ	ß
E0	à	á	â	ã	ä	å	æ	ç	è	é	ê	ë	ì	í	î	ï
F0	ð	ñ	ò	ó	ô	õ	ö	÷	ø	ù	ú	û	ü	ý	þ	ÿ

Note: To enter "A", first you have to read 40 in a row and 01 in a column and type 41.

4.5 Window Character Set Information

Code	Short Name	Description	Country
1250	Central Europe	Windows Latin 2	Albania, Croatia, Czech, Faeroese, Hungarian, Polish, Romanian, Serbian(Latin), Slovak, Slovenian
1251	Cyrillic	Windows Cyrillic (Slavic)	Byelorussian, Bulgarian, Russian, Ukrainian
1252	Latin 1	Windows Latin 1 (ANSI)	Afrikaans, Catalan, Danish, Dutch, English, USA, Canada, New Zealand, Austria, Ireland, South Africa, Finnish, French, Belgium, Switzerland, Luxembourg, German, Austria, Liechtenstein, Italian, Icelandic, Indonesian, Norwegian, Portuguese, Brazil, Spanish, Mexico, Swedish
1253	Greek	Windows Greek	Greek
1254	Turkish	Windows Latin 5 (Turkish)	Turkish
1255	Hebrew	Windows Hebrew	Hebrew
1256	Arabic	Windows Arabic	Saudi Arabia, Iraq, Egypt, Libya, Algeria, Morocco, Tunisia, Oman, Yemen, Syria, Jordan, Lebanon, Kuwait, United Arab Emirates, Bahrain, Qatar, Farsi
1257	Baltic	Windows Baltic Rim	Estonian, Latvian, Lithuanian
1258	Vietnam		Vietnam
874	Thai		Thai
932	Japanese Shift-JIS		Japan
936	Simplified Chinese GBK	Simplified Chinese	Chinese, Singapore
949	Korean	Complete Hangul	Korea
950	Traditional Chinese BIG5	Traditional Chinese	Taiwan, HongKong



MEMO

MEMO





MEMO



CL5000J SERIES

Label Printing Scale



CAS BLDG., # 440-1, SUNGNAE-DONG,
GANGDONG-GU, SEOUL, KOREA

TEL_ 82 2 2225 3500

FAX_ 82 2 475 4668

www.globalcas.com