

ECS-H+ SERIES COUNTING SCALE



Feature:

- 20 keys embossed membrane keyboard.
- Responds quickly with accurate weights.
- Application programs include : Piece counting, prese tare, piece checking alarm, accumulation.
- Battery provide up to 70 hours of continues use (without back light).

Options(Additional) :

RS-232 interface, connect to computer, LP-50 label Printer or Tgup mini printer.

ECS-H+ SERIES COUNTING SCALE

Specification:

Model	ECS+ Series / ECS-H+ Series			
Display	20mm Digit high LCD, white color LED back light			
Capacity	3kg	6kg	15kg	30kg
Readability	0.05	0.1	0.2	0.5
Pan size	230mm x 300mm			
Keyboard	20 keys embossed membrane keyboard			
Housing	ABS plastic			
Max. Divisions	2X3,000e			
ADC	Sigma delta			
ADC update	<1/10 second			
Operate Temp	-10°C~+40°C			
Power	AC adapter (12v/500 mA), internal rechargeable battery (6V/4Ah)			
Gross Weight	5.1kg			
Packing	Master carton 4 in 1, gross weight 23.5kg, dimension 0.162 m ³			

Dimension(mm):

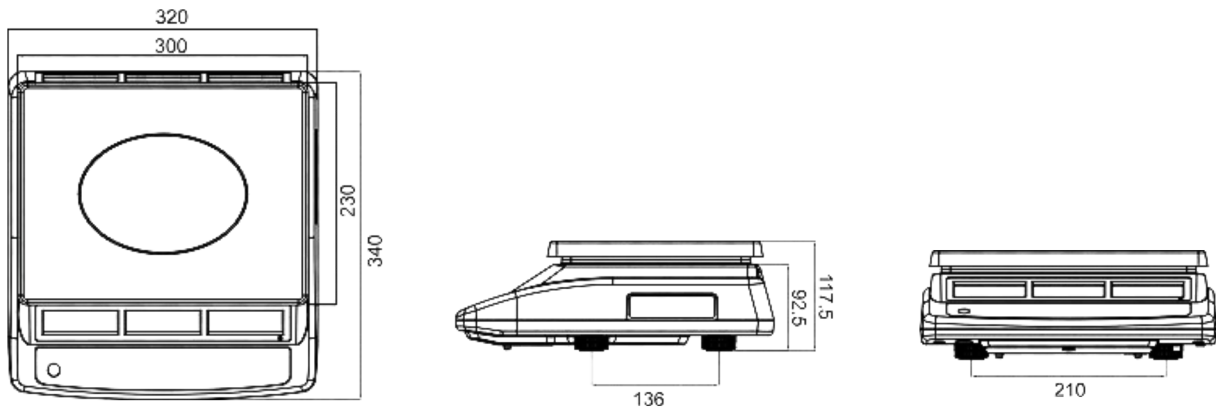

We Represent



Intertek

ENDEL WEIGH SYSTEMS LLC

P. O. Box 45588, Office No. 1412, Al Manara, Nr. JW Marriot Marquis, Business Bay, Dubai.

T.: +971-4-3522077 | F.: +971-4-3522088 | M.: +971-50-7343742

E.: sales@dubaiweighing.com | W.: www.dubaiweighing.com