

EJB-NB+ SERIES PRECISION BALANCE



Feature:

- 7 keys embossed membrane keyboard
- percentage weighing, counting, accumulation
- selectable weighing unit
- Standard RS-232 interface
- Attached wind shielding (<1500g)
- Battery provide up to 40 hours of continuous use (without back light)

Options:

- Below weighing
- USB interface
- Bluetooth

EJB-NB+ SERIES PRECISION BALANCE

Specification:

Model	EJB-NB+			
Display	16.5mm LCD, with white color LED backlight			
Capacity	150g / 1500g / 6000g			
Readability	0.001g / 0.01g / 0.1g			
Pan size	Round 80mm(150g), 120mm(300~1500g), Square 140X150mm (≥1500)			
Keyboard	7 keys embossed membrane keyboard			
Housing	ABS plastic			
Max. Divisions	30,000	60,000	150,000	200,000
ADC	Sigma delta			
ADC update	≤1/10 second			
Operate Temp	0°C~+40°C			
Power	AC adapter (12v/500 mA), internal rechargeable battery (6V/4Ah)			
Gross Weight	Capacities ≤1500g--2.9kg Capacities > 1500--2.7kg			
Packing	Master carton 4 in 1 packing, dimension 0.122m ³			

Dimension(mm):

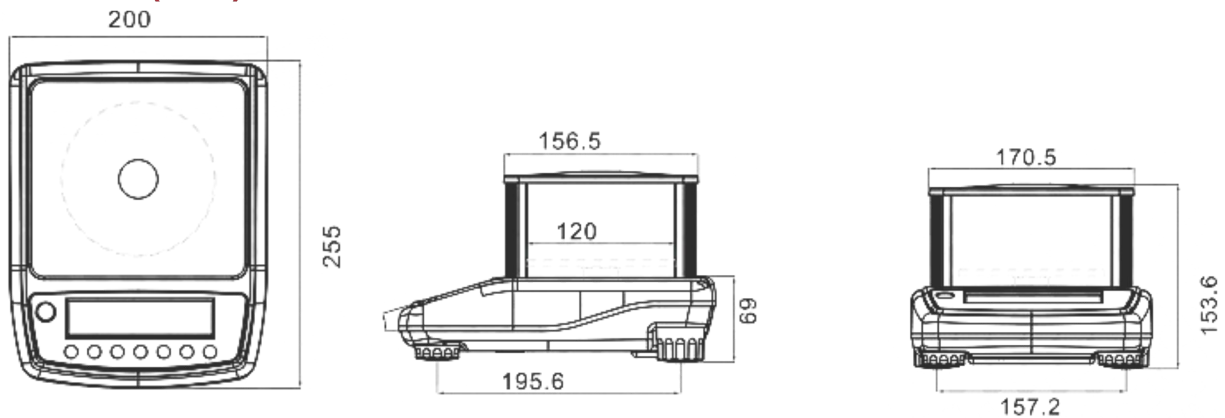

We Represent



Intertek

ENDEL WEIGH SYSTEMS LLC

P. O. Box 45588, Office No. 1412, Al Manara, Nr. JW Marriot Marquis, Business Bay, Dubai.

T.: +971-4-3522077 | F.: +971-4-3522088 | M.: +971-50-7343742

E.: sales@dubaiweighing.com | W.: www.dubaiweighing.com